

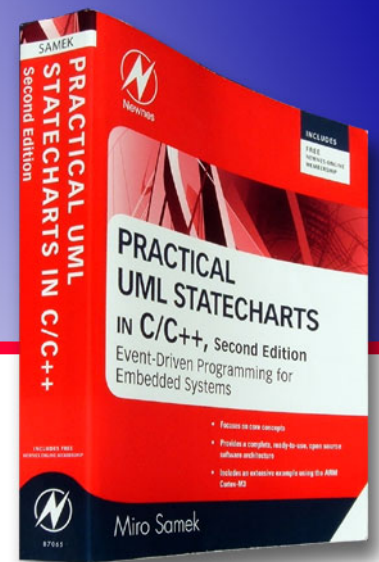

**Quantum<sup>®</sup>Leaps**  
innovating embedded systems



# A Crash Course in UML State Machines

**Miro Samek**  
**Quantum Leaps, LLC**

Article based on Chapter 2 of the book  
"Practical UML Statecharts in C/C++ Second Edition"  
Published online at  
[www.Embedded.com](http://www.Embedded.com)  
March 2009

Copyright © Quantum Leaps, LLC

[www.quantum-leaps.com](http://www.quantum-leaps.com)  
[www.state-machine.com](http://www.state-machine.com)



## Table of Contents

<b>Part 1</b>	<b>The oversimplification of the event-action paradigm .....</b>	<b>1-1</b>
1.1	The Oversimplification of the Event-Action Paradigm .....	1-1
1.2	Basic State Machine Concepts .....	1-3
1.2.1	States .....	1-3
1.2.2	State Diagrams .....	1-4
1.2.3	State Diagrams versus Flowcharts .....	1-4
1.2.4	Extended State Machines .....	1-5
1.2.5	Guard Conditions .....	1-6
1.2.6	Events .....	1-7
1.2.7	Actions and Transitions .....	1-8
1.2.8	Run-to-Completion Execution Model .....	1-8
1.3	References .....	1-8
<b>Part 2</b>	<b>UML Extensions to the Traditional FSM Formalism .....</b>	<b>2-1</b>
2.1	Reuse of Behavior in Reactive Systems .....	2-1
2.1.1	Hierarchically Nested States .....	2-1
2.1.2	Behavioral Inheritance .....	2-3
2.1.3	Liskov Substitution Principle for States .....	2-3
2.2	Orthogonal Regions .....	2-4
2.3	Entry and Exit Actions .....	2-5
2.4	Internal Transitions .....	2-6
2.5	Transition Execution Sequence .....	2-7
2.6	Local versus External Transitions .....	2-8
2.7	Event Deferral .....	2-9
2.8	UML Statecharts and Automatic Code Synthesis .....	2-9
2.9	The Limitations of the UML State Diagrams .....	2-10
2.10	UML State Machine Semantics: An Exhaustive Example .....	2-11
2.11	References .....	2-13
<b>Part 3</b>	<b>Designing a UML state machine .....</b>	<b>3-1</b>
3.1	Problem Specification .....	3-1
3.2	High-Level Design .....	3-2
3.3	Scavenging for Reuse .....	3-2
3.4	Elaborating Composite States .....	3-3
3.5	Refining the Behavior .....	3-3
3.6	Final Touches .....	3-4
3.7	Executing the Example Code .....	3-5
3.8	Summary .....	3-6
3.9	References .....	3-7
<b>Contact Information</b> .....	<b>3-1</b>	

## Part 1 The oversimplification of the event-action paradigm

---

*One place we could really use help is in optimizing IF-THEN-ELSE constructs. Most programs start out fairly well structured. As bugs are found and features are grafted on, IFs and ELSEs are added until no human being really has a good idea how data flows through a function. Pretty printing helps, but does not reduce the complexity of 15 nested IF statements.*

—Jack Ganssle, “Break Points,” ESP Magazine, January 1991

Traditional, sequential programs can be structured as a single flow of control, using standard constructs such as loops and nested function calls. Such programs represent most of the execution context in the location of the program counter, in the procedure call tree, and in the temporary variables allocated on the stack

Event-driven programs, in contrast, require a series of fine-granularity event-handler functions for handling events. These event-handler functions must execute quickly and always return to the main event-loop, so no context can be preserved in the call tree and the program counter. In addition, all stack variables disappear across calls to the separate event-handlers. Thus, event-driven programs rely heavily on static variables to preserve the execution context from one event-handler invocation to the next.

Consequently, one of the biggest challenges of event-driven programming lies in managing the execution context represented as data. The main problem here is that the context data must somehow feed back into the control flow of the event-handler code so that each event handler can execute only the actions appropriate in the current context. Traditionally, this dependence on the context very often leads to deeply nested if-else constructs that direct the flow of control based on the context data.

If you could eliminate even a fraction of these conditional branches (a.k.a. “spaghetti” code), the software would be much easier to understand, test, and maintain, and the sheer number of convoluted execution paths through the code would drop radically, typically by orders of magnitude. Techniques based on state machines are capable of achieving exactly this—a dramatic reduction of the different paths through the code and simplification of the conditions tested at each branching point.

In this article series I briefly introduce UML state machines that represent the current state of the art in the long evolution of these techniques. My intention is not to give a complete, formal discussion of UML state machines, which the official OMG specification [1-1] covers comprehensively and with formality. Rather, my goal in this article series is to lay a foundation by establishing basic terminology, introducing basic notation, clarifying semantics, and giving some code examples. This chapter is restricted to only a subset of those state machine features that are arguably most fundamental. The emphasis is on the role of UML state machines in practical, everyday programming rather than mathematical abstractions.

### 1.1 The Oversimplification of the Event-Action Paradigm

---

The currently dominating approach to structuring event-driven software is the ubiquitous “event-action” paradigm, in which events are directly mapped to the code that is supposed to be executed in response. The event-action paradigm is an important stepping stone for understanding state machines, so in this section I briefly describe how it works in practice.

I will use an example from the graphical user interface (GUI) domain, given that GUIs make exemplary event-driven systems. In the book *Constructing the User Interface with Statecharts* [1-2], Ian Horrocks discusses a simple GUI calculator application distributed in millions of copies as a sample program with Microsoft Visual Basic, in which he found a number of serious problems. As Horrocks notes, the point of this analysis is not to criticize this particular program but to identify the shortcomings of the general principles used in its construction.

When you launch the Visual Basic calculator (available from the companion Website at [www.state-machine.com/psicc2/](http://www.state-machine.com/psicc2/), in the directory <qp>\resources\vb\calc.exe), you will certainly find out that most of the time it correctly adds, subtracts, multiplies, and divides (see Figure 1-1(a)). What's not to like? However, play with the program for a while longer and you can discover many corner cases in which the calculator provides misleading results, freezes, or crashes altogether.

**Figure 1-1 Visual Basic calculator before the crash (a) and after a crash with a runtime error (b).**

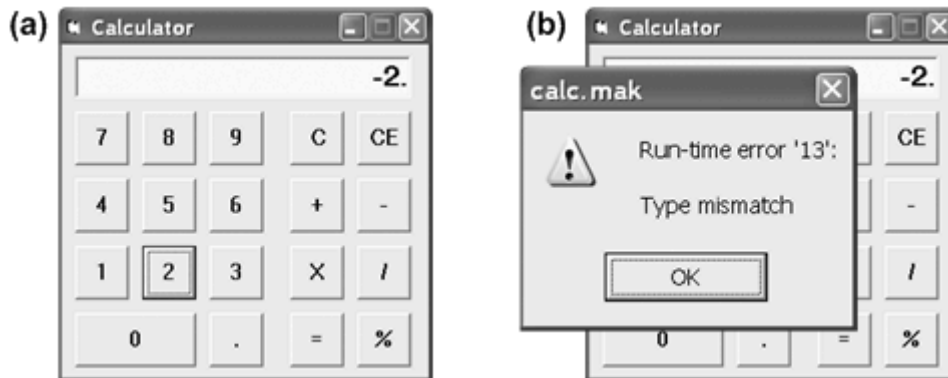

For example, the Visual Basic calculator often has problems with the “-” event; just try the following sequence of operations: 2, -, -, -, 2, =. The application crashes with a runtime error (see Figure 1-1(b)). This is because the same button (-) is used to negate a number and to enter the subtraction operator. The correct interpretation of the “-” button-click event, therefore, depends on the context, or mode, in which it occurs. Likewise, the CE (Cancel Entry) button occasionally works erroneously—try 2, x, CE, 3, =, and observe that CE had no effect, even though it appears to cancel the 2 entry from the display. Again, CE should behave differently when canceling an operand than canceling an operator. As it turns out, the application handles the CE event always the same way, regardless of the context. At this point, you probably have noticed an emerging pattern. The application is especially vulnerable to events that require different handling depending on the context.

This is not to say that the Visual Basic calculator does not attempt to handle the context. Quite the contrary, if you look at the calculator code (available from the companion Website at [www.state-machine.com/psicc2/](http://www.state-machine.com/psicc2/), in the directory <qp>\resources\vb\calc.frm), you'll notice that managing the context is in fact the main concern of this application. The code is littered with a multitude of global variables and flags that serve only one purpose: handling the context. For example, `DecimalFlag` indicates that a decimal point has been entered, `OpFlag` represents a pending operation, `LastInput` indicates the type of the last button press event, `NumOps` denotes the number of operands, and so on. With this representation, the context of the computation is represented ambiguously, so it is difficult to tell precisely in which mode the application is at any given time. Actually, the application has no notion of any single mode of operation but rather a bunch of tightly coupled and overlapping conditions of operation determined by values of the global variables and flags.

**Listing 1-1 shows the conditional logic in which the event-handler procedure for the operator events (+, -, \*, and /) attempts to determine whether the - (minus) button-click should be treated as negation or subtraction.**

```
Private Sub Operator_Click(Index As Integer)
    . . .
    Select Case NumOps
        Case 0
            If Operator(Index).Caption = "-" And LastInput <> "NEG" Then
                ReadOut = "-" & ReadOut
                LastInput = "NEG"
            End If
    End Select
End Sub
```

```
Case 1
  Op1 = ReadOut
  If Operator(Index).Caption = "-" And LastInput <> "NUMS" And
                                OpFlag <> "=" Then
    ReadOut = "-"
    LastInput = "NEG"
  End If
. . .
```

The approach exemplified in [Listing 1-1](#) is a fertile ground for the “corner case” behavior (a.k.a. bugs) for at least three reasons:

- It always leads to convoluted conditional logic (a.k.a. “spaghetti” code).
- Each branching point requires evaluation of a complex expression.
- Switching between different modes requires modifying many variables, which can easily lead to inconsistencies.

Convoluted conditional expressions like the one shown in [Listing 1-1](#), scattered throughout the code, are unnecessarily complex and expensive to evaluate at runtime. They are also notoriously difficult to get right, even by experienced programmers, as the bugs still lurking in the Visual Basic calculator attest. This approach is insidious because it appears to work fine initially, but doesn’t scale up as the problem grows in complexity. Apparently, the calculator application (overall only seven event handlers and some 140 lines of Visual Basic code including comments) is just complex enough to be difficult to get right with this approach.

The faults just outlined are rooted in the oversimplification of the event-action paradigm. The Visual Basic calculator example makes it clear, I hope, that an event alone does not determine the actions to be executed in response to that event. The current context is at least equally important. The prevalent event-action paradigm, however, recognizes only the dependency on the event-type and leaves the handling of the context to largely ad hoc techniques that all too easily degenerate into spaghetti code.

## 1.2 Basic State Machine Concepts

The event-action paradigm can be extended to explicitly include the dependency on the execution context. As it turns out, the behavior of most event-driven systems can be divided into a relatively small number of chunks, where event responses within each individual chunk indeed depend only on the current event-type but no longer on the sequence of past events (the context). In other words, the event-action paradigm is still applied, but only locally within each individual chunk.

A common and straightforward way of modeling behavior based on this idea is through a finite state machine (FSM). In this formalism, “chunks of behavior” are called states, and change of behavior (i.e., change in response to any event) corresponds to change of state and is called a state transition. An FSM is an efficient way to specify constraints of the overall behavior of a system. Being in a state means that the system responds only to a subset of all allowed events, produces only a subset of possible responses, and changes state directly to only a subset of all possible states.

The concept of an FSM is important in programming because it makes the event handling explicitly dependent on both the event-type and on the execution context (state) of the system. When used correctly, a state machine becomes a powerful “spaghetti reducer” that drastically cuts down the number of execution paths through the code, simplifies the conditions tested at each branching point, and simplifies the transitions between different modes of execution.

### 1.2.1 States

A state captures the relevant aspects of the system’s history very efficiently. For example, when you strike a key on a keyboard, the character code generated will be either an uppercase or a lowercase character, depending on

whether the Caps Lock is active. Therefore, the keyboard’s behavior can be divided into two chunks (states): the “default” state and the “caps\_locked” state. (Most keyboards actually have an LED that indicates that the keyboard is in the “caps\_locked” state.) The behavior of a keyboard depends only on certain aspects of its history, namely whether the Caps Lock key has been pressed, but not, for example, on how many and exactly which other keys have been pressed previously. A state can abstract away all possible (but irrelevant) event sequences and capture only the relevant ones.

To relate this concept to programming, this means that instead of recording the event history in a multitude of variables, flags, and convoluted logic, you rely mainly on just one state variable that can assume only a limited number of a priori determined values (e.g., two values in case of the keyboard). The value of the state variable crisply defines the current state of the system at any given time. The concept of state reduces the problem of identifying the execution context in the code to testing just the state variable instead of many variables, thus eliminating a lot of conditional logic. Actually, in all but the most basic state machine implementation techniques, such as the “nested-switch statement” technique, even the explicit testing of the state variable disappears from the code, which reduces the “spaghetti” further still. Moreover, switching between different states is vastly simplified as well, because you need to reassign just one state variable instead of changing multiple variables in a self-consistent manner.

### 1.2.2 State Diagrams

FSMs have an expressive graphical representation in the form of state diagrams. These diagrams are directed graphs in which nodes denote states and connectors denote state transitions.

For example, Figure 1-2 shows a UML state transition diagram corresponding to the computer keyboard state machine. In UML, states are represented as rounded rectangles labeled with state names. The transitions, represented as arrows, are labeled with the triggering events followed optionally by the list of executed actions. The initial transition originates from the solid circle and specifies the starting state when the system first begins. Every state diagram should have such a transition, which should not be labeled, since it is not triggered by an event. The initial transition can have associated actions.

**Figure 1-2 state diagram representing the computer keyboard state machine.**

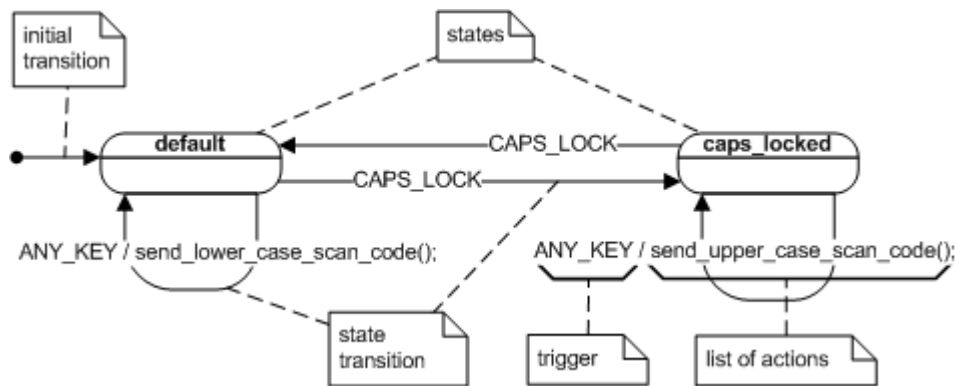

### 1.2.3 State Diagrams versus Flowcharts

Newcomers to the state machine formalism often confuse state diagrams with flowcharts. For a long time, the UML specification wasn’t helping in this respect because it used to lump activity graphs in the state machine package (the new UML 2 [1-1] has finally separated activity diagrams from state machines). Activity diagrams are essentially elaborate flowcharts.

Figure 1-3 shows a comparison of a state diagram with a flowchart. A state machine (panel (a)) performs actions in response to explicit triggers. In contrast, the flowchart (panel (b)) does not need explicit triggers but rather transitions from node to node in its graph automatically upon completion of activities.

**Figure 1-3: Comparison of (a) state machine (statechart) with (b) activity diagram (flowchart).**

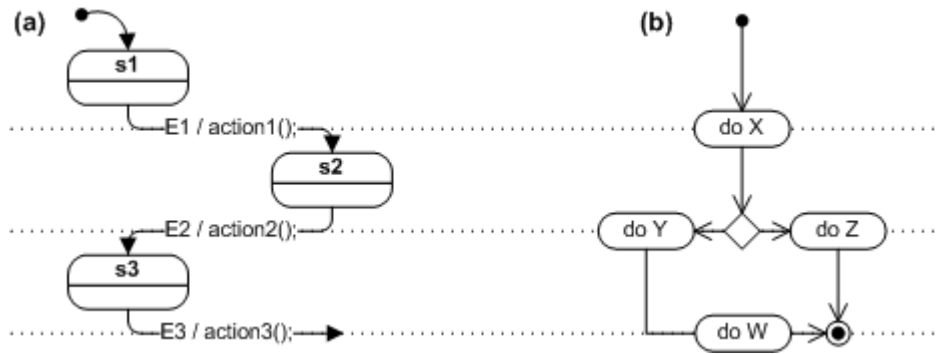

Graphically, compared to state diagrams, flowcharts reverse the sense of vertices and arcs. In a state diagram, the processing is associated with the arcs (transitions), whereas in a flowchart, it is associated with the vertices. A state machine is idle when it sits in a state waiting for an event to occur. A flowchart is busy executing activities when it sits in a node. Figure 1-3 attempts to show that reversal of roles by aligning the arcs of the statecharts with the processing stages of the flowchart.

You can compare a flowchart to an assembly line in manufacturing because the flowchart describes the progression of some task from beginning to end (e.g., transforming source code input into object code output by a compiler). A state machine generally has no notion of such a progression. A computer keyboard, for example, is not in a more advanced stage when it is in the “caps\_locked” state, compared to being in the “default” state; it simply reacts differently to events. A state in a state machine is an efficient way of specifying a particular behavior, rather than a stage of processing.

The distinction between state machines and flowcharts is especially important because these two concepts represent two diametrically opposed programming paradigms: event-driven programming (state machines) and transformational programming (flowcharts). You cannot devise effective state machines without constantly thinking about the available events. In contrast, events are only a secondary concern (if at all) for flowcharts.

### 1.2.4 Extended State Machines

One possible interpretation of state for software systems is that each state represents one distinct set of valid values of the whole program memory. Even for simple programs with only a few elementary variables, this interpretation leads to an astronomical number of states. For example, a single 32-bit integer could contribute to over 4 billion different states. Clearly, this interpretation is not practical, so program variables are commonly dissociated from states. Rather, the complete condition of the system (called the extended state) is the combination of a qualitative aspect (the state) and the quantitative aspects (the extended state variables). In this interpretation, a change of variable does not always imply a change of the qualitative aspects of the system behavior and therefore does not lead to a change of state [1-3].

State machines supplemented with variables are called extended state machines. Extended state machines can apply the underlying formalism to much more complex problems than is practical without including extended state variables. For instance, suppose the behavior of the keyboard depends on the number of characters typed on it so far and that after, say, 1,000 keystrokes, the keyboard breaks down and enters the final state. To model this behavior in a state machine without memory, you would need to introduce 1,000 states (e.g., pressing a key in state stroke123 would lead to state stroke124, and so on), which is clearly an impractical proposition. Alternatively, you could construct an extended state machine with a key\_count down-counter variable. The

counter would be initialized to 1,000 and decremented by every keystroke without changing state. When the counter reached zero, the state machine would enter the final state.

**Figure 1-4: Extended state machine of “cheap keyboard” with extended state variable `key_count` and various guard conditions.**

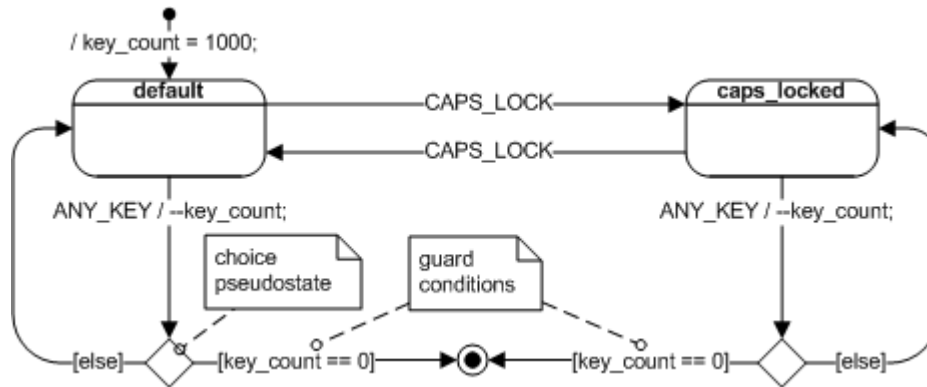

The state diagram from Figure 1-4 is an example of an extended state machine, in which the complete condition of the system (called the extended state) is the combination of a qualitative aspect—the “state”—and the quantitative aspects—the extended state variables (such as the down-counter `key_count`). In extended state machines, a change of a variable does not always imply a change of the qualitative aspects of the system behavior and therefore does not always lead to a change of state.

The obvious advantage of extended state machines is flexibility. For example, extending the lifespan of the “cheap keyboard” from 1,000 to 10,000 keystrokes would not complicate the extended state machine at all. The only modification required would be changing the initialization value of the `key_count` down-counter in the initial transition.

### 1.2.5 Guard Conditions

This flexibility of extended state machines comes with a price, however, because of the complex coupling between the “qualitative” and the “quantitative” aspects of the extended state. The coupling occurs through the guard conditions attached to transitions, as shown in Figure 1-4.

Guard conditions (or simply guards) are Boolean expressions evaluated dynamically based on the value of extended state variables and event parameters (see the discussion of events and event parameters in the next section). Guard conditions affect the behavior of a state machine by enabling actions or transitions only when they evaluate to TRUE and disabling them when they evaluate to FALSE. In the UML notation, guard conditions are shown in square brackets (e.g., `[key_count == 0]`).

The need for guards is the immediate consequence of adding memory (extended state variables) to the state machine formalism. Used sparingly, extended state variables and guards make up an incredibly powerful mechanism that can immensely simplify designs. But don’t let the fancy name (“guard”) and the concise UML notation fool you. When you actually code an extended state machine, the guards become the same IFs and ELSEs that you wanted to eliminate by using the state machine in the first place. Too many of them, and you’ll find yourself back in square one (“spaghetti”), where the guards effectively take over handling of all the relevant conditions in the system.

Indeed, abuse of extended state variables and guards is the primary mechanism of architectural decay in designs based on state machines. Usually, in the day-to-day battle, it seems very tempting, especially to programmers new to state machine formalism, to add yet another extended state variable and yet another guard condition (another if or an else) rather than to factor out the related behavior into a new qualitative aspect of the system—the state. From my experience in the trenches, the likelihood of such an architectural decay is directly proportional

to the overhead (actual or perceived) involved in adding or removing states. (That's why I don't particularly like the popular state-table technique of implementing state machines, because adding a new state requires adding and initializing a whole new column in the table.)

One of the main challenges in becoming an effective state machine designer is to develop a sense for which parts of the behavior should be captured as the "qualitative" aspects (the "state") and which elements are better left as the "quantitative" aspects (extended state variables). In general, you should actively look for opportunities to capture the event history (what happened) as the "state" of the system, instead of storing this information in extended state variables. For example, the Visual Basic calculator uses an extended state variable `DecimalFlag` to remember that the user entered the decimal point to avoid entering multiple decimal points in the same number. However, a better solution is to observe that entering a decimal point really leads to a distinct state "entering\_the\_fractional\_part\_of\_a\_number," in which the calculator ignores decimal points. This solution is superior for a number of reasons. The lesser reason is that it eliminates one extended state variable and the need to initialize and test it. The more important reason is that the state-based solution is more robust because the context information is used very locally (only in this particular state) and is discarded as soon as it becomes irrelevant. Once the number is correctly entered, it doesn't really matter for the subsequent operation of the calculator whether that number had a decimal point. The state machine moves on to another state and automatically "forgets" the previous context. The `DecimalFlag` extended state variable, on the other hand, "lays around" well past the time the information becomes irrelevant (and perhaps outdated!). Worse, you must not forget to reset `DecimalFlag` before entering another number or the flag will incorrectly indicate that indeed the user once entered the decimal point, but perhaps this happened in the context of the previous number.

Capturing behavior as the quantitative "state" has its disadvantages and limitations, too. First, the state and transition topology in a state machine must be static and fixed at compile time, which can be too limiting and inflexible. Sure, you can easily devise "state machines" that would modify themselves at runtime (this is what often actually happens when you try to recode "spaghetti" as a state machine). However, this is like writing self-modifying code, which indeed was done in the early days of programming but was quickly dismissed as a generally bad idea. Consequently, "state" can capture only static aspects of the behavior that are known a priori and are unlikely to change in the future. For example, it's fine to capture the entry of a decimal point in the calculator as a separate state "entering\_the\_fractional\_part\_of\_a\_number," because a number can have only one fractional part, which is both known a priori and is not likely to change in the future. However, implementing the "cheap keyboard" without extended state variables and guard conditions would be practically impossible. This example points to the main weakness of the quantitative "state," which simply cannot store too much information (such as the wide range of keystroke counts). Extended state variables and guards are thus a mechanism for adding extra runtime flexibility to state machines.

## 1.2.6 Events

In the most general terms, an event is an occurrence in time and space that has significance to the system. Strictly speaking, in the UML specification the term event refers to the type of occurrence rather than to any concrete instance of that occurrence [1-1]. For example, Keystroke is an event for the keyboard, but each press of a key is not an event but a concrete instance of the Keystroke event. Another event of interest for the keyboard might be Power-on, but turning the power on tomorrow at 10:05:36 will be just an instance of the Power-on event.

An event can have associated parameters, allowing the event instance to convey not only the occurrence of some interesting incident but also quantitative information regarding that occurrence. For example, the Keystroke event generated by pressing a key on a computer keyboard has associated parameters that convey the character scan code as well as the status of the Shift, Ctrl, and Alt keys.

An event instance outlives the instantaneous occurrence that generated it and might convey this occurrence to one or more state machines. Once generated, the event instance goes through a processing life cycle that can consist of up to three stages. First, the event instance is received when it is accepted and waiting for processing (e.g., it is placed on the event queue). Later, the event instance is dispatched to the state machine, at which point it becomes the current event. Finally, it is consumed when the state machine finishes processing the event instance. A consumed event instance is no longer available for processing.

## 1.2.7 Actions and Transitions

When an event instance is dispatched, the state machine responds by performing actions, such as changing a variable, performing I/O, invoking a function, generating another event instance, or changing to another state. Any parameter values associated with the current event are available to all actions directly caused by that event.

Switching from one state to another is called state transition, and the event that causes it is called the triggering event, or simply the trigger. In the keyboard example, if the keyboard is in the “default” state when the CapsLock key is pressed, the keyboard will enter the “caps\_locked” state. However, if the keyboard is already in the “caps\_locked” state, pressing CapsLock will cause a different transition—from the “caps\_locked” to the “default” state. In both cases, pressing CapsLock is the triggering event.

In extended state machines, a transition can have a guard, which means that the transition can “fire” only if the guard evaluates to TRUE. A state can have many transitions in response to the same trigger, as long as they have nonoverlapping guards; however, this situation could create problems in the sequence of evaluation of the guards when the common trigger occurs. The UML specification intentionally does not stipulate any particular order; rather, UML puts the burden on the designer to devise guards in such a way that the order of their evaluation does not matter. Practically, this means that guard expressions should have no side effects, at least none that would alter evaluation of other guards having the same trigger.

## 1.2.8 Run-to-Completion Execution Model

All state machine formalisms, including UML statecharts, universally assume that a state machine completes processing of each event before it can start processing the next event. This model of execution is called run to completion, or RTC.

In the RTC model, the system processes events in discrete, indivisible RTC steps. New incoming events cannot interrupt the processing of the current event and must be stored (typically in an event queue) until the state machine becomes idle again. These semantics completely avoid any internal concurrency issues within a single state machine. The RTC model also gets around the conceptual problem of processing actions associated with transitions, where the state machine is not in a well-defined state (is between two states) for the duration of the action. During event processing, the system is unresponsive (unobservable), so the ill-defined state during that time has no practical significance.

Note, however, that RTC does not mean that a state machine has to monopolize the CPU until the RTC step is complete. The preemption restriction only applies to the task context of the state machine that is already busy processing events. In a multitasking environment, other tasks (not related to the task context of the busy state machine) can be running, possibly preempting the currently executing state machine. As long as other state machines do not share variables or other resources with each other, there are no concurrency hazards.

The key advantage of RTC processing is simplicity. Its biggest disadvantage is that the responsiveness of a state machine is determined by its longest RTC step.<sup>4</sup> Achieving short RTC steps can often significantly complicate real-time designs.

## 1.3 References

- |       |   |
|-------|---|
| [1-1] | Object Management Group, “Unified Modeling Language: Superstate version 2.1.2”, formal/07-11-02, see also <a href="http://www.omg.org/docs/formal/07-11-02.pdf">http://www.omg.org/docs/formal/07-11-02.pdf</a> . |
| [1-2] | Horrocks, Ian, “Constructing the User Interface with Statecharts”, Addison-Wesley, 1999.  |
| [1-3] | Selic, Bran, Garth Gulleckson, and Paul T. Ward, “Real-Time Object-Oriented Modeling”, John Wiley & Sons, 1994.   |

## Part 2 UML Extensions to the Traditional FSM Formalism

---

Though the traditional FSMs are an excellent tool for tackling smaller problems, it's also generally known that they tend to become unmanageable, even for moderately involved systems. Due to the phenomenon known as state explosion, the complexity of a traditional FSM tends to grow much faster than the complexity of the reactive system it describes. This happens because the traditional state machine formalism inflicts repetitions. For example, if you try to represent the behavior of the Visual Basic calculator (introduced in part 1 of this article) with a traditional FSM, you'll immediately notice that many events (e.g., the Clear event) are handled identically in many states. A conventional FSM, however, has no means of capturing such a commonality and requires repeating the same actions and transitions in many states. What's missing in the traditional state machines is the mechanism for factoring out the common behavior in order to share it across many states.

The formalism of statecharts, invented by David Harel in the 1980s [2-1], addresses exactly this shortcoming of the conventional FSMs. Statecharts provide a very efficient way of sharing behavior so that the complexity of a statechart no longer explodes but tends to faithfully represent the complexity of the reactive system it describes. Obviously, formalism like this is a godsend to embedded systems programmers (or any programmers working with event-driven systems) because it makes the state machine approach truly applicable to real-life problems.

UML state machines, known also as UML statecharts [2-2], are object-based variants of Harel statecharts and incorporate several concepts defined in ROOMcharts, a variant of the statechart defined in the Real-time Object-Oriented Modeling (ROOM) language [2-3]. UML statecharts are extended state machines with characteristics of both Mealy and Moore automata. In statecharts, actions generally depend on both the state of the system and the triggering event, as in a Mealy automaton. Additionally, UML statecharts provide optional entry and exit actions, which are associated with states rather than transitions, as in a Moore automaton.

### 2.1 Reuse of Behavior in Reactive Systems

---

All reactive systems seem to reuse behavior in a similar way. For example, the characteristic look and feel of all GUIs results from the same pattern, which the Windows guru Charles Petzold calls the "Ultimate Hook" [2-4]. The pattern is brilliantly simple: A GUI system dispatches every event first to the application (e.g., Windows calls a specific function inside the application, passing the event as an argument). If not handled by the application, the event flows back to the system. This establishes a hierarchical order of event processing. The application, which is conceptually at a lower level of the hierarchy, has the first shot at every event; thus the application can choose to react in any way it likes. At the same time, all unhandled events flow back to the higher level (i.e., to the GUI system), where they are processed according to the standard look and feel. This is an example of programming by difference because the application programmer needs to code only the differences from the standard system behavior.

#### 2.1.1 Hierarchically Nested States

Harel statecharts bring the "Ultimate Hook" pattern to the logical conclusion by combining it with the state machine formalism. The most important innovation of statecharts over the classical FSMs is the introduction of hierarchically nested states (that's why statecharts are also called hierarchical state machines, or HSMs). The semantics associated with state nesting are as follows (see [Figure 2-1\(a\)](#)): If a system is in the nested state "s11" (called the substate), it also (implicitly) is in the surrounding state "s1" (called the superstate). This state machine will attempt to handle any event in the context of state "s11," which conceptually is at the lower level of the hierarchy. However, if state "s11" does not prescribe how to handle the event, the event is not quietly discarded as in a traditional "flat" state machine; rather, it is automatically handled at the higher level context of the superstate "s1." This is what is meant by the system being in state "s11" as well as "s1." Of course, state nesting is not limited to one level only, and the simple rule of event processing applies recursively to any level of nesting.

**Figure 2-1: UML notation for hierarchically nested states (a), and a state model of a toaster oven in which states “toasting” and “baking” share the common transition from state “heating” to “door\_open” (b).**

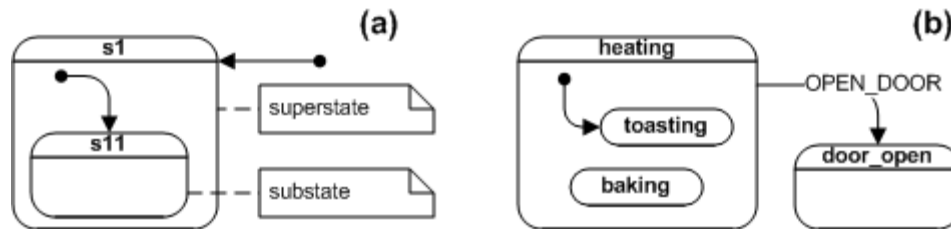

States that contain other states are called composite states; conversely, states without internal structure are called simple states. A nested state is called a direct substate when it is not contained by any other state; otherwise, it is referred to as a transitively nested substate.

Because the internal structure of a composite state can be arbitrarily complex, any hierarchical state machine can be viewed as an internal structure of some (higher-level) composite state. It is conceptually convenient to define one composite state as the ultimate root of state machine hierarchy. In the UML specification, every state machine has a top state (the abstract root of every state machine hierarchy), which contains all the other elements of the entire state machine. The graphical rendering of this all-enclosing top state is optional [2-2].

As you can see, the semantics of hierarchical state decomposition are designed to facilitate sharing of behavior through the direct support for the “Ultimate Hook” pattern. The substates (nested states) need only define the differences from the superstates (surrounding states). A substate can easily reuse the common behavior from its superstate(s) by simply ignoring commonly handled events, which are then automatically handled by higher-level states. In this manner, the substates can share all aspects of behavior with their superstates. For example, in a state model of a toaster oven shown in Figure 2-1(b), states “toasting” and “baking” share a common transition DOOR\_OPEN to the “door\_open” state, defined in their common superstate “heating.”

The aspect of state hierarchy emphasized most often is abstraction—an old and powerful technique for coping with complexity. Instead of facing all aspects of a complex system at the same time, it is often possible to ignore (abstract away) some parts of the system. Hierarchical states are an ideal mechanism for hiding internal details because the designer can easily zoom out or zoom in to hide or show nested states. Although abstraction by itself does not reduce overall system complexity, it is valuable because it reduces the amount of detail you need to deal with at one time. As Grady Booch [2-5] notes:

*... we are still constrained by the number of things that we can comprehend at one time, but through abstraction, we use chunks of information with increasingly greater semantic content.*

However valuable abstraction in itself might be, you cannot cheat your way out of complexity simply by hiding it inside composite states. However, the composite states don’t simply hide complexity, they also actively reduce it through the powerful mechanism of reuse (the “Ultimate Hook” pattern). Without such reuse, even a moderate increase in system complexity often leads to an explosive increase in the number of states and transitions. For example, if you transform the statechart from Figure 2-1(b) to a classical flat state machine,<sup>5</sup> you must repeat one transition (from heating to “door\_open”) in two places: as a transition from “toasting” to “door\_open” and from “baking” to “door\_open.” Avoiding such repetitions allows HSMs to grow proportionally to system complexity. As the modeled system grows, the opportunity for reuse also increases and thus counteracts the explosive increase in states and transitions typical for traditional FSMs.

## 2.1.2 Behavioral Inheritance

Hierarchical states are more than merely the “grouping of [nested] state machines together without additional semantics” [2-6]. In fact, hierarchical states have simple but profound semantics. Nested states are also more than just “great diagrammatic simplification when a set of events applies to several substates” [2-7]. The savings in the number of states and transitions are real and go far beyond less cluttered diagrams. In other words, simpler diagrams are just a side effect of behavioral reuse enabled by state nesting.

The fundamental character of state nesting comes from the combination of abstraction and hierarchy, which is a traditional approach to reducing complexity and is otherwise known in software as inheritance. In OOP, the concept of class inheritance describes relations between classes of objects. Class inheritance describes the “is a ...” relationship among classes. For example, class Bird might derive from class Animal. If an object is a bird (instance of the Bird class), it automatically is an animal, because all operations that apply to animals (e.g., eating, eliminating, reproducing) also apply to birds. But birds are more specialized, since they have operations that are not applicable to animals in general. For example, flying() applies to birds but not to fish.

The benefits of class inheritance are concisely summarized by Gamma and colleagues [2-8]:

*Inheritance lets you define a new kind of class rapidly in terms of an old one, by reusing functionality from parent classes. It allows new classes to be specified by difference rather than created from scratch each time. It lets you get new implementations almost for free, inheriting most of what is common from the ancestor classes.*

As you saw in the previous section, all these basic characteristics of inheritance apply equally well to nested states (just replace the word class with state), which is not surprising because state nesting is based on the same fundamental “is a ...” classification as object-oriented class inheritance. For example, in a state model of a toaster oven, state “toasting” nests inside state “heating.” If the toaster is in the “toasting” state, it automatically is in the “heating” state because all behavior pertaining to “heating” applies also to “toasting” (e.g., the heater must be turned on). But “toasting” is more specialized because it has behaviors not applicable to “heating” in general. For example, setting toast color (light or dark) applies to “toasting” but not to “baking.”

In the case of nested states, the “is a ...” (is-a-kind-of) relationship merely needs to be replaced by the “is in ...” (is-in-a-state) relationship; otherwise, it is the same fundamental classification. State nesting allows a substate to inherit state behavior from its ancestors (superstates); therefore, it’s called behavioral inheritance.

The concept of inheritance is fundamental in software construction. Class inheritance is essential for better software organization and for code reuse, which makes it a cornerstone of OOP. In the same way, behavioral inheritance is essential for efficient use of HSMs and for behavior reuse, which makes it a cornerstone of event-driven programming. The book “Practical UML Statecharts in C/C++, Second Edition” presents a mini-catalog of state patterns shows ways to structure HSMs to solve recurring problems. Not surprisingly, behavioral inheritance plays the central role in all these patterns.

## 2.1.3 Liskov Substitution Principle for States

Identifying the relationship among substates and superstates as inheritance has many practical implications. Perhaps the most important is the Liskov Substitution Principle (LSP) applied to state hierarchy. In its traditional formulation for classes, LSP requires that a subclass can be freely substituted for its superclass. This means that every instance of the subclass should be compatible with the instance of the superclass and that any code designed to work with the instance of the superclass should continue to work correctly if an instance of the subclass is used instead.

Because behavioral inheritance is just a special kind of inheritance, LSP can be applied to nested states as well as classes. LSP generalized for states means that the behavior of a substate should be consistent with the superstate. For example, all states nested inside the heating state of the toaster oven (e.g., toasting or baking) should share the same basic characteristics of the heating state. In particular, if being in the heating state means

that the heater is turned on, then none of the substates should turn the heater off (without transitioning out of the heating state). Turning the heater off and staying in the toasting or baking state would be inconsistent with being in the heating state and would indicate poor design (violation of the LSP).

Compliance with the LSP allows you to build better (more correct) state hierarchies and make efficient use of abstraction. For example, in an LSP-compliant state hierarchy, you can safely zoom out and work at the higher level of the “heating” state (thus abstracting away the specifics of “toasting” and “baking”). As long as all the substates are consistent with their superstate, such abstraction is meaningful. On the other hand, if the substates violate basic assumptions of being in the superstate, zooming out and ignoring the specifics of the substates will be incorrect.

## 2.2 Orthogonal Regions

Hierarchical state decomposition can be viewed as exclusive-OR operation applied to states. For example, if a system is in the “heating” superstate (Figure 2-1(b)), it means that it’s either in “toasting” substate OR the “baking” substate. That is why the “heating” superstate is called an OR-state.

UML statecharts also introduce the complementary AND-decomposition. Such decomposition means that a composite state can contain two or more orthogonal regions (orthogonal means independent in this context) and that being in such a composite state entails being in all its orthogonal regions simultaneously [2-9].

Orthogonal regions address the frequent problem of a combinatorial increase in the number of states when the behavior of a system is fragmented into independent, concurrently active parts. For example, apart from the main keypad, a computer keyboard has an independent numeric keypad. From the previous discussion, recall the two states of the main keypad already identified: “default” and “caps\_locked” (Figure 1-2 in part 1 of this article). The numeric keypad also can be in two states—“numbers” and “arrows”—depending on whether Num Lock is active. The complete state space of the keyboard in the standard decomposition is the cross-product of the two components (main keypad and numeric keypad) and consists of four states: “default–numbers,” “default–arrows,” “caps\_locked–numbers,” and “caps\_locked–arrows.” However, this is unnatural because the behavior of the numeric keypad does not depend on the state of the main keypad and vice versa. Orthogonal regions allow you to avoid mixing the independent behaviors as a cross-product and, instead, to keep them separate, as shown in Figure 2-2.

**Figure 2-2: Two orthogonal regions (main keypad and numeric keypad) of a computer keyboard.**

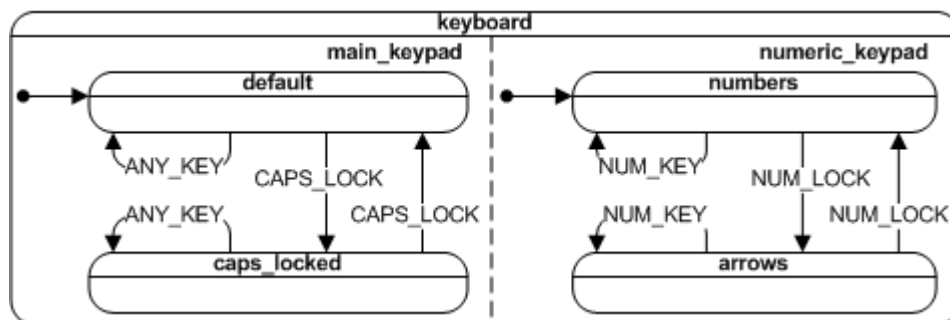

Note that if the orthogonal regions are fully independent of each other, their combined complexity is simply additive, which means that the number of independent states needed to model the system is simply the sum  $k + l + m + \dots$ , where  $k, l, m, \dots$  denote numbers of OR-states in each orthogonal region. The general case of mutual dependency, on the other hand, results in multiplicative complexity, so in general, the number of states needed is the product  $k \cdot l \cdot m \cdot \dots$ .

In most real-life situations, however, orthogonal regions are only approximately orthogonal (i.e., they are not independent). Therefore, UML statecharts provide a number of ways for orthogonal regions to communicate and

synchronize their behaviors. From these rich sets of (sometimes complex) mechanisms, perhaps the most important is that orthogonal regions can coordinate their behaviors by sending event instances to each other.

Even though orthogonal regions imply independence of execution (i.e., some kind of concurrency), the UML specification does not require that a separate thread of execution be assigned to each orthogonal region (although it can be implemented that way). In fact, most commonly, orthogonal regions execute within the same thread. The UML specification only requires that the designer not rely on any particular order in which an event instance will be dispatched to the involved orthogonal regions.

## 2.3 Entry and Exit Actions

Every state in a UML statechart can have optional entry actions, which are executed upon entry to a state, as well as optional exit actions, which are executed upon exit from a state. Entry and exit actions are associated with states, not transitions. Regardless of how a state is entered or exited, all its entry and exit actions will be executed. Because of this characteristic, statecharts behave like Moore automata. The UML notation for state entry and exit actions is to place the reserved word “entry” (or “exit”) in the state right below the name compartment, followed by the forward slash and the list of arbitrary actions (see [Figure 2-3](#)).

Figure 2-3: Toaster oven state machine with entry and exit actions.

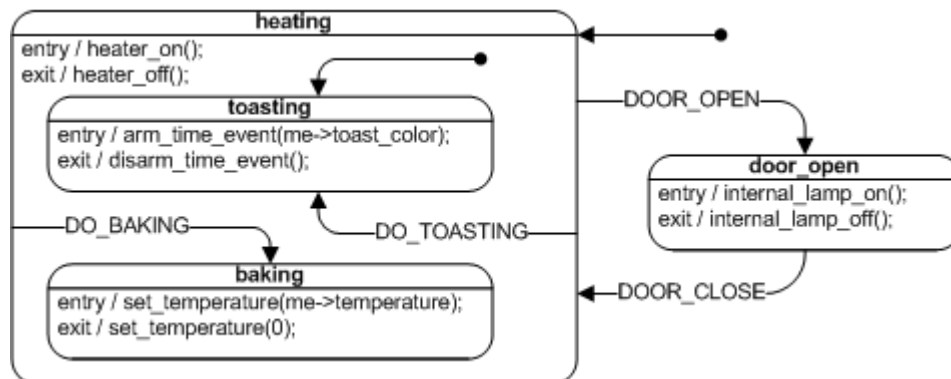

The value of entry and exit actions is that they provide means for guaranteed initialization and cleanup, very much like class constructors and destructors in OOP. For example, consider the “door\_open” state from [Figure 2-1\(b\)](#), which corresponds to the toaster oven behavior while the door is open. This state has a very important safety-critical requirement: Always disable the heater when the door is open. Additionally, while the door is open, the internal lamp illuminating the oven should light up.

Of course, you could model such behavior by adding appropriate actions (disabling the heater and turning on the light) to every transition path leading to the “door\_open” state (the user may open the door at any time during “baking” or “toasting” or when the oven is not used at all). You also should not forget to extinguish the internal lamp with every transition leaving the “door\_open” state. However, such a solution would cause the repetition of actions in many transitions. More important, such an approach is error-prone in view of changes to the state machine (e.g., the next programmer working on a new feature, such as top-browning, might simply forget to disable the heater on transition to “door\_open”).

Entry and exit actions allow you to implement the desired behavior in a much safer, simpler, and more intuitive way. As shown in [Figure 2-3](#), you could specify that the exit action from “heating” disables the heater, the entry action to “door\_open” lights up the oven lamp, and the exit action from “door\_open” extinguishes the lamp. The use of entry and exit action is superior to placing actions on transitions because it avoids repetitions of those actions on transitions and eliminates the basic safety hazard of leaving the heater on while the door is open. The

semantics of exit actions guarantees that, regardless of the transition path, the heater will be disabled when the toaster is not in the “heating” state.

Because entry actions are executed automatically whenever an associated state is entered, they often determine the conditions of operation or the identity of the state, very much as a class constructor determines the identity of the object being constructed. For example, the identity of the “heating” state is determined by the fact that the heater is turned on. This condition must be established before entering any substate of “heating” because entry actions to a substate of “heating,” like “toasting,” rely on proper initialization of the “heating” superstate and perform only the differences from this initialization. Consequently, the order of execution of entry actions must always proceed from the outermost state to the innermost state.

Not surprisingly, this order is analogous to the order in which class constructors are invoked. Construction of a class always starts at the very root of the class hierarchy and follows through all inheritance levels down to the class being instantiated. The execution of exit actions, which corresponds to destructor invocation, proceeds in the exact reverse order, starting from the innermost state (corresponding to the most derived class).

## 2.4 Internal Transitions

Very commonly, an event causes only some internal actions to execute but does not lead to a change of state (state transition). In this case, all actions executed comprise the internal transition. For example, when you type on your keyboard, it responds by generating different character codes. However, unless you hit the Caps Lock key, the state of the keyboard does not change (no state transition occurs). In UML, this situation should be modeled with internal transitions, as shown in Figure 2-4. The UML notation for internal transitions follows the general syntax used for exit (or entry) actions, except instead of the word entry (or exit) the internal transition is labeled with the triggering event (e.g., see the internal transition triggered by the ANY\_KEY event in Figure 2-4).

**Figure 2-4: UML state diagram of the keyboard state machine with internal transitions.**

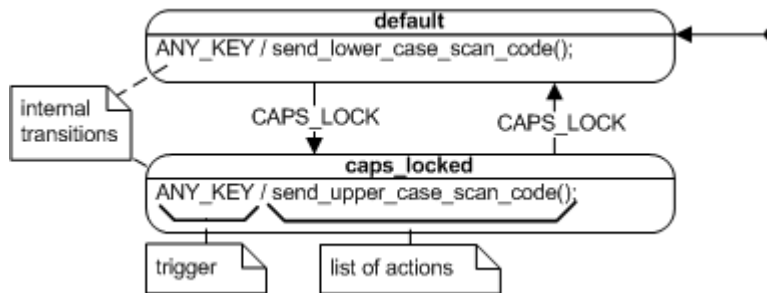

In the absence of entry and exit actions, internal transitions would be identical to self-transitions (transitions in which the target state is the same as the source state). In fact, in a classical Mealy automaton, actions are associated exclusively with state transitions, so the only way to execute actions without changing state is through a self-transition (depicted as a directed loop in Figure 1-2 from the first part of this article). However, in the presence of entry and exit actions, as in UML statecharts, a self-transition involves the execution of exit and entry actions and therefore it is distinctively different from an internal transition.

In contrast to a self-transition, no entry or exit actions are ever executed as a result of an internal transition, even if the internal transition is inherited from a higher level of the hierarchy than the currently active state. Internal transitions inherited from superstates at any level of nesting act as if they were defined directly in the currently active state.

## 2.5 Transition Execution Sequence

State nesting combined with entry and exit actions significantly complicates the state transition semantics in HSMs compared to the traditional FSMs. When dealing with hierarchically nested states and orthogonal regions, the simple term current state can be quite confusing. In an HSM, more than one state can be active at once. If the state machine is in a leaf state that is contained in a composite state (which is possibly contained in a higher-level composite state, and so on), all the composite states that either directly or transitively contain the leaf state are also active. Furthermore, because some of the composite states in this hierarchy might have orthogonal regions, the current active state is actually represented by a tree of states starting with the single top state at the root down to individual simple states at the leaves. The UML specification refers to such a state tree as state configuration [2-2].

Figure 2-5: State roles in a state transition.

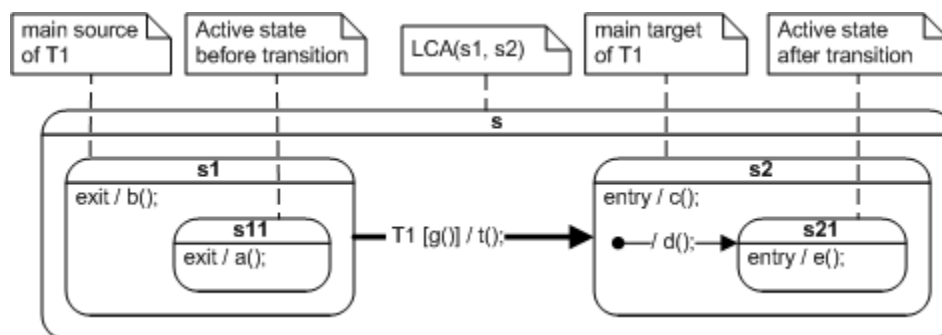

In UML, a state transition can directly connect any two states. These two states, which may be composite, are designated as the main source and the main target of a transition. Figure 2-5 shows a simple transition example and explains the state roles in that transition. The UML specification prescribes that taking a state transition involves executing the following actions in the following sequence (see [2-8, Section 15.3.14]):

1. Evaluate the guard condition associated with the transition and perform the following steps only if the guard evaluates to TRUE.
2. Exit the source state configuration.
3. Execute the actions associated with the transition.
4. Enter the target state configuration.

The transition sequence is easy to interpret in the simple case of both the main source and the main target nesting at the same level. For example, transition T1 shown in Figure 2-5 causes the evaluation of the guard g(); followed by the sequence of actions: a(); b(); t(); c(); d(); and e(), assuming that the guard g() evaluates to TRUE.

However, in the general case of source and target states nested at different levels of the state hierarchy, it might not be immediately obvious how many levels of nesting need to be exited. The UML specification prescribes that a transition involves exiting all nested states from the current active state (which might be a direct or transitive substate of the main source state) up to, but not including, the least common ancestor (LCA) state of the main source and main target states. As the name indicates, the LCA is the lowest composite state that is simultaneously a superstate (ancestor) of both the source and the target states. As described before, the order of execution of exit actions is always from the most deeply nested state (the current active state) up the hierarchy to the LCA but without exiting the LCA. For instance, the LCA(s1,s2) of states "s1" and "s2" shown in Figure 2-5 is state "s."

Entering the target state configuration commences from the level where the exit actions left off (i.e., from inside the LCA). As described before, entry actions must be executed starting from the highest-level state down the

state hierarchy to the main target state. If the main target state is composite, the UML semantics prescribes to “drill” into its submachine recursively using the local initial transitions. The target state configuration is completely entered only after encountering a leaf state that has no initial transitions.

**NOTE:** The HSM implementation described in the book “Practical UML Statecharts in C/C++” preserves the essential order of exiting the source configuration followed by entering the target state configuration, but executes the actions associated with the transition entirely in the context of the source state, that is, before exiting the source state configuration. Specifically, the implemented transition sequence is as follows:

1. Evaluate the guard condition associated with the transition and perform the following steps only if the guard evaluates to TRUE.
2. Execute the actions associated with the transition.
3. Atomically exit the source state configuration and enter the target state configuration.

For example, the transition T1 shown in [Figure 2-5](#) will cause the evaluation of the guard  $g()$ ; followed by the sequence of actions:  $t()$ ;  $a()$ ;  $b()$ ;  $c()$ ;  $d()$ ; and  $e()$ , assuming that the guard  $g()$  evaluates to TRUE.

One big problem with the UML transition sequence is that it requires executing actions associated with the transition after destroying the source state configuration but before creating the target state configuration. In the analogy between exit actions in state machines and destructors in OOP, this situation corresponds to executing a class method after partially destroying an object. Of course, such action is illegal in OOP. As it turns out, it is also particularly awkward to implement for state machines.

Executing actions associated with a transition is much more natural in the context of the source state—the same context in which the guard condition is evaluated. Only after the guard and the transition actions execute, the source state configuration is exited and the target state configuration is entered atomically. That way the state machine is observable only in a stable state configuration, either before or after the transition, but not in the middle.

## 2.6 Local versus External Transitions

Before UML 2, the only transition semantics in use was the external transition, in which the main source of the transition is always exited and the main target of the transition is always entered. UML 2 preserved the “external transition” semantics for backward compatibility, but also introduced also a new kind of transition called local transition [2-8, Section 15.3.15]. For many transition topologies, external and local transitions are actually identical. However, a local transition doesn’t cause exit from the main source state if the main target state is a substate of the main source. In addition, local state transition doesn’t cause exit and reentry to the target state if the main target is a superstate of the main source state.

[Figure 2-6](#) contrasts local (a) and external (b) transitions. In the top row, you see the case of the main source containing the target. The local transition does not cause exit from the source, while the external transition causes exit and re-entry to the source. In the bottom row of [Figure 2-6](#), you see the case of the target containing the source. The local transition does not cause entry to the target, whereas the external transition causes exit and reentry to the target.

**Figure 2-6: Local (a) versus external transitions (b). QP implements only the local transitions.**

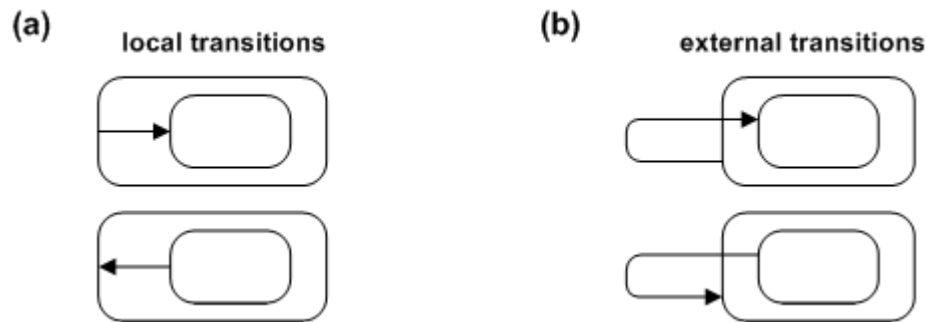

The HSM implementation described in the book “Practical UML Statecharts in C/C++” supports exclusively the local state transition semantics.

## 2.7 Event Deferral

Sometimes an event arrives at a particularly inconvenient time, when a state machine is in a state that cannot handle the event. In many cases, the nature of the event is such that it can be postponed (within limits) until the system enters another state, in which it is much better prepared to handle the original event.

UML state machines provide a special mechanism for deferring events in states. In every state, you can include a clause ‘deferred / [event list]’. If an event in the current state’s deferred event list occurs, the event will be saved (deferred) for future processing until a state is entered that does not list the event in its deferred event list. Upon entry to such state, the UML state machine will automatically recall any saved event(s) that are no longer deferred and process them as if they have just arrived.

**NOTE:** The HSM implementation described in the book “Practical UML Statecharts in C/C++” does not directly support the UML-style event deferral. However, the “Deferred Event” state pattern presented in the book shows how to approximate this feature in a much less expensive way by explicitly deferring and recalling events.

## 2.8 UML Statecharts and Automatic Code Synthesis

UML statecharts provide sufficiently well-defined semantics for building executable state models. Indeed, several design automation tools on the market support various versions of statecharts (see the sidebar “Design Automation Tools Supporting Statecharts”). The commercially available design automation tools typically not only automatically generate code from statecharts but also enable debugging and testing of the state models at the graphical level [2-7].

But what does automatic code generation really mean? And more important, what kind of code is actually generated by such statechart-based tools?

Many people understand automatic code synthesis as the generation of a program to solve a problem from a statement of the problem specification. Statechart-based tools cannot provide this because a statechart is just a higher-level (mostly visual) solution rather than the statement of the problem.

As far as the automatically generated code is concerned, the statechart-based tools can autonomously generate only so-called “housekeeping code” [2-7]. The modeler explicitly must provide all the application-specific code, such as action and guard expressions, to the tool. The role of housekeeping code is to “glue” the various action and guard expressions together to ensure proper state machine execution in accordance with the statechart semantics. For example, synthesized code typically handles event queuing, event dispatching, guard evaluation,

or transition chain execution (including exit and entry of appropriate states). Almost universally, the tools also encompass some kind of real-time framework that integrates tightly with the underlying operating system.

#### DESIGN AUTOMATION TOOLS SUPPORTING STATECHARTS

Some of the computer-aided software-engineering (CASE) tools with support for statecharts currently available on the market are:

- Telelogic Statemate, [www.telelogic.com](http://www.telelogic.com) (the tool originally developed by I-Logix, Inc. acquired by Telelogic in 2006, which in turn is in the process of being acquired by IBM) .
- Telelogic Rhapsody, [www.telelogic.com](http://www.telelogic.com) .
- Rational Suite Development Studio Real-Time, Rational Software Corporation, [www.ibm.com/software/rational](http://www.ibm.com/software/rational) (Rational was acquired by IBM in 2006)
- ARTiSAN Studio, ARTiSAN Software Tools, Ltd., [www.artisansw.com](http://www.artisansw.com) .
- Stateflow, The Mathworks, [www.mathworks.com](http://www.mathworks.com)
- VisualSTATE, IAR Systems, [www.iar.com](http://www.iar.com)

## 2.9 The Limitations of the UML State Diagrams

Statecharts have been invented as “a visual formalism for complex systems” [2-1], so from their inception, they have been inseparably associated with graphical representation in the form of state diagrams. However, it is important to understand that the concept of HSMs transcends any particular notation, graphical or textual. The UML specification [2-2] makes this distinction apparent by clearly separating state machine semantics from the notation.

However, the notation of UML statecharts is not purely visual. Any nontrivial state machine requires a large amount of textual information (e.g., the specification of actions and guards). The exact syntax of action and guard expressions isn’t defined in the UML specification, so many people use either structured English or, more formally, expressions in an implementation language such as C, C++, or Java [2-10]. In practice, this means that UML statechart notation depends heavily on the specific programming language.

Nevertheless, most of the statecharts semantics are heavily biased toward graphical notation. For example, state diagrams poorly represent the sequence of processing, be it order of evaluation of guards or order of dispatching events to orthogonal regions. The UML specification sidesteps these problems by putting the burden on the designer not to rely on any particular sequencing. But, when you actually implement UML state machines, you will always have full control over the order of execution, so the restrictions imposed by UML semantics will be unnecessarily restrictive. Similarly, statechart diagrams require a lot of plumbing gear (pseudostates, like joins, forks, junctions, choicepoints, etc.) to represent the flow of control graphically. These elements are essentially the old flowchart in disguise, which structured programming techniques proved far less significant a long time ago. In other words, these elements of the graphical notation do not add much value in representing flow of control as compared to plain structured code.

This is not to criticize the graphical notation of statecharts. In fact, it is remarkably expressive and can scarcely be improved. Rather, I want merely to point out some shortcomings and limitations of the pen-and-paper diagrams.

The UML notation and semantics are really geared toward computerized design automation tools. A UML state machine, as represented in a tool, is not just the state diagram, but rather a mixture of graphical and textual representation that precisely captures both the state topology and the actions. The users of the tool can get several complementary views of the same state machine, both visual and textual, whereas the generated code is just one of the many available views.

## 2.10 UML State Machine Semantics: An Exhaustive Example

The very rich UML state machine semantics might be quite confusing to newcomers, and even to fairly experienced designers. Wouldn't it be great if you could generate the exact sequence of actions for every possible transition so that you know for sure what actions get executed and in which order?

In this section, I present an executable example of a hierarchical state machine shown in [Figure 2-7](#) that contains all possible transition topologies up to four levels of state nesting. The state machine contains six states: "s," "s1," "s11," "s2," "s21," and "s211." The state machine recognizes nine events A through I, which you can generate by typing either uppercase or lowercase letters on your keyboard. All the actions of this state machine consist only of `printf` statements that report the status of the state machine to the screen. This complete example with source code is available from the companion Website for the book "Practical UML Statecharts in C/C++, Second Edition" at [www.state-machine.com/psicc2](http://www.state-machine.com/psicc2). The executable console application for Windows is located in the directory `<qp>\qpc\examples\80x86\dos\watcom\1\qhsmtst\dbg\`. The name of the application is `QHSMTST.EXE`.

**Figure 2-7: Hypothetical state machine that contains all possible state transition topologies up to four levels of state nesting**

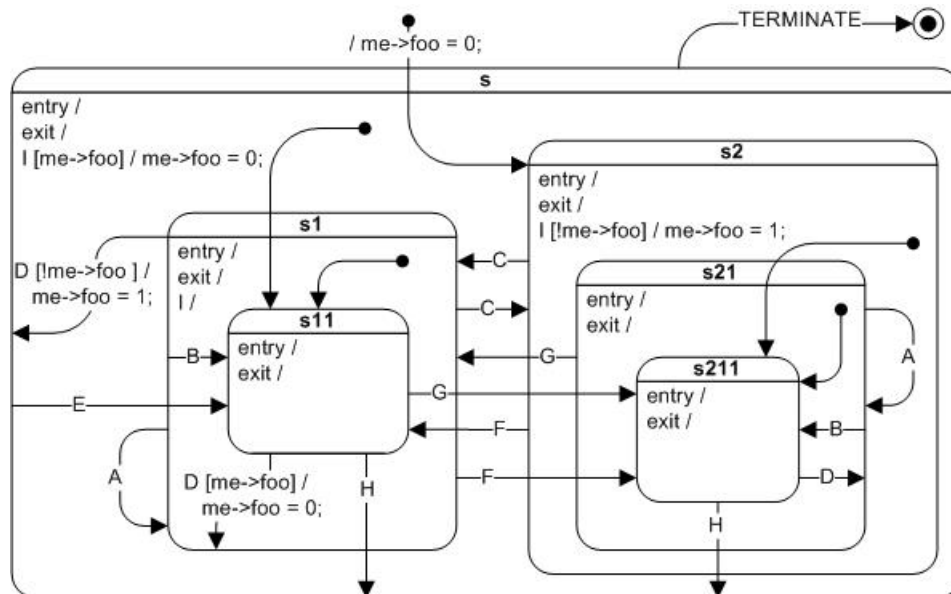

[Figure 2-8](#) shows an example run of the `QHSMTST.EXE` application. Note the line numbers in parentheses at the left edge of the window, added for reference. Line (1) shows the effect of the topmost initial transition. Note the sequence of entry actions and initial transitions ending at the "s211-ENTRY" printout. Injecting events into the state machine begins in line (2). Every generated event (shown on a gray background) is followed by the sequence of exit actions from the source state configuration followed by entry actions and initial transitions entering the target state configuration. From these printouts you can always determine the order of transition processing as well as the active state, which is the last state entered. For instance, the active state before injecting event G in line (2) is "s211" because this is the last state entered in the previous line.

**Figure 2-8: QHSMTST.EXE example application running in the command window. The line numbers in brackets to the right are added for reference.**

```

Command Prompt - dbg\qhsmtst
QHsmIst example. built on Sep 25 2007 at 09:11:31,
QEP/C: 3.4.01.
Press ESC to quit...
(1) top-INIT;s-ENTRY;s2-ENTRY;s2-INIT;s21-ENTRY;s211-ENTRY;
(2) >G: s21-G;s211-EXIT;s21-EXIT;s2-EXIT;s1-ENTRY;s1-INIT;s11-ENTRY;
(3) >I: s1-I;
(4) >A: s1-A;s11-EXIT;s1-EXIT;s1-ENTRY;s1-INIT;s11-ENTRY;
(5) >D: s1-D;s11-EXIT;s1-EXIT;s-INIT;s1-ENTRY;s11-ENTRY;
(6) >D: s11-D;s11-EXIT;s1-INIT;s11-ENTRY;
(7) >C: s1-C;s11-EXIT;s1-EXIT;s2-ENTRY;s2-INIT;s21-ENTRY;s211-ENTRY;
(8) >E: s-E;s211-EXIT;s21-EXIT;s2-EXIT;s1-ENTRY;s11-ENTRY;
(9) >E: s-E;s11-EXIT;s1-EXIT;s1-ENTRY;s11-ENTRY;
(10) >G: s11-G;s11-EXIT;s1-EXIT;s2-ENTRY;s21-ENTRY;s211-ENTRY;
(11) >I: s2-I;
(12) >I: s-I;
(13) >*: Bye, Bye!
  
```

Per the semantics of UML state machines, the event G injected in line (2) is handled in the following way. First, the active state (“s211”) attempts to handle the event. However, as you can see in the state diagram in [Figure 2-7](#), state “s211” does not prescribe how to handle event G. Therefore the event is passed on to the next higher-level state in the hierarchy, which is state “s21.” The superstate “s21” prescribes how to handle event G because it has a state transition triggered by G. State “s21” executes the actions associated with the transition (printout “s21-G,” in line (2) of [Figure 2-8](#)). Next the state executes the transition chain that exits the source state configuration and enters the target state configuration. The transition chain starts with execution of exit actions from the active state through higher and higher levels of hierarchy. Next the target state configuration is entered in exact opposite order, that is, starting from highest levels of state hierarchy down to the lowest. The transition G from state “s21” terminates at state “s1.” However, the transition chain does not end at the direct target of the transition but continues via the initial transition defined in the direct target state “s21.” Finally, a new active state is established by entering state “s11” that has no initial transition.

In line (3) of [Figure 2-8](#), you see how the statechart handles an internal transition. Event I is injected while state machine is in state “s11.” Again, the active state does not prescribe how to handle event I, so it is passed on to the next level of state hierarchy, that is, to state “s1.” State “s1” has an internal transition triggered by I defined in its internal transition compartment; therefore “s1” handles the event (printout “s1-I,” in line (3)). And at this point the processing ends. No change of state ever occurs in the internal transition, even if such transition is inherited from higher levels of state hierarchy.

In the UML state machines internal transitions are different from self-transitions. Line (4) of [Figure 2-8](#) demonstrates the difference. The state machine is in state “s11” when event A is injected. As in the case of the internal transition, the active state “s11” does not prescribe how to handle event A, so the event is passed on to the superstate “s1.” The superstate has a self-transition triggered by A and so it executes actions associated with the transition (printout “s1-A,” in line (4)). This time, however, a regular transition is taken, which requires exiting the source state configuration and entering the target state configuration.

UML statecharts are extended state machines, meaning that in general, the actions executed by the state machine can depend also on the value of the extended state variables. Consider for example event D injected in line (5). The active state “s11” has transition D, but this transition has a guard `[me->foo]`. The variable `me->foo` is an extended state variable of the state machine from [Figure 2-7](#). You can see that `me->foo` is initialized to 0 on the topmost initial transition. Therefore the guard `[me->foo]`, which is a test of `me->foo` against 0, evaluates to FALSE. The guard condition temporarily disables the transition D in state “s11,” which is handled as though state “s11” did not define the transition in the first place. Therefore, the event D is passed on to the next higher level, that is, to state “s1.” State “s1” has transition D with a complementary guard `[!me->foo]`. This time, the guard evaluates to TRUE and the transition D in state “s1” is taken. As indicated in the diagram, the transition action changes the value of the extended state variable `me->foo` to 1. Therefore when another event D is injected again in line (6), the guard condition `[me->foo]` on transition D in state “s11” evaluates to TRUE and this transition is taken, as indicated in line (6) of [Figure 2-8](#).

Line (7) of [Figure 2-8](#) demonstrates that all exit and entry actions are always executed, regardless of the exit and entry path. The main target of transition C from “s1” is “s2.” The initial transition in the main target state goes

“over” the substate “s21” all the way to the substate “s211.” However, the entry actions don’t skip the entry to “s21.” This example demonstrates the powerful concept of guaranteed cleanup of the source state configuration and guaranteed initialization of the target state configuration, regardless of the complexity of the exit or entry path.

Interestingly, in hierarchical state machines, the same transition can cause different sequences of exit actions, depending on which state inherits the transition. For example, in lines (8) and (9) of [Figure 2-8](#), event E triggers the exact same state transition defined in the superstate “s.” However, the responses in lines (8) and (9) are different because transition E fires from different state configurations—once when “s211” is active (line (8)) and next when “s11” is active (line (9)).

Finally, lines (11) and (12) of [Figure 2-8](#) demonstrate that guard conditions can also be used on internal transitions. States “s2” and d both define internal transition I with complementary guard conditions. In line (11), the guard [ !me->foo ] enables internal transition instate “s2.” In line (12) the same guard disables the internal transition in “s2,” and therefore the internal transition defined in the superstate d is executed.

You can learn much more about the semantics of UML state machines by injecting various events to the QHSMTST.EXE application and studying its output. Because the state machine from [Figure 2-7](#) has been specifically designed to contain all possible state transition configurations up to level 4 of nesting, this example can “answer” virtually all your questions regarding the semantics of statecharts. Moreover, you can use the source code that actually implements the state machine (located in <pp>\qpc\examples\80x86\dos\watcom\1\qhsmtst\qhsmtst.c) as a template for implementing your own statecharts. Simply look up applicable fragments in the diagram from [Figure 2-7](#) and check how they have been implemented in qhsmtst.c.

## 2.11 References

- |        |   |
|--------|---|
| [2-1]  | Harel, David, “Statecharts: A Visual Formalism for Complex Systems”, Science of Computer Programming, 8, 1987, pp. 231-274, <a href="http://www.wisdom.weizmann.ac.il/~dharel/SCANNED.PAPERS/Statecharts.pdf">http://www.wisdom.weizmann.ac.il/~dharel/SCANNED.PAPERS/Statecharts.pdf</a> . |
| [2-2]  | Object Management Group, “Unified Modeling Language: Superstate version 2.1.2”, formal/07-11-02, see also <a href="http://www.omg.org/docs/formal/07-11-02.pdf">http://www.omg.org/docs/formal/07-11-02.pdf</a>   |
| [2-3]  | Selic, Bran, Garth Gulleckson, and Paul T. Ward, “Real-Time Object-Oriented Modeling”, John Wiley & Sons, 1994.   |
| [2-4]  | Petzold, Charles, “Programming Windows: The Definite Developer’s Guide to Programming Windows”, Microsoft Press, 1996   |
| [2-5]  | Booch, Grady, “Object-Oriented Analysis and Design with Applications”, Addison-Wesley, 1994.  |
| [2-6]  | Mellor, Stephen, “UML Point/Counterpoint: Modeling Complex Behavior Simply,” Embedded Systems Programming, March 2000, <a href="http://www.embedded.com/2000/0003/0003feat1.htm">http://www.embedded.com/2000/0003/0003feat1.htm</a>  |
| [2-7]  | Douglass, Bruce Powel, Doing Hard Time: Developing Real-Time Systems with UML, Objects, Frameworks, and Patterns”, Addison-Wesley, 1999.  |
| [2-8]  | Gamma, Erich, Richard Helm, Ralph Johnson, and John Vlissides, “Design Patterns, Elements of Reusable Object-Oriented Software”, Addison-Wesley, 1995.  |
| [2-9]  | Harel, David, and Michal Politi, “Modeling Reactive Systems with Statecharts”, The STATEMATE Approach, McGraw-Hill, 1998.   |
| [2-10] | Douglass, Bruce Powel, “UML Statecharts,” Embedded Systems Programming, January 1999, pp. 22–42.  |

## Part 3 Designing a UML state machine

---

Designing a UML state machine, as any design, is not a strict science. Typically it is an iterative and incremental process: You design a little, code a little, test a little, and so on. In that manner you may converge at a correct design in many different ways, and typically also, more than one correct HSM design satisfies a given problem specification. To focus the discussion, here I walk you through a design of an UML state machine that implements correctly the behavior of a simple calculator similar to the Visual Basic calculator used at the beginning of this chapter. Obviously, the presented solution is just one of the many possible.

**Figure 3-1: A simple electronic calculator used as a model for the statechart example.**



### 3.1 Problem Specification

---

The calculator (see [Figure 3-1](#)) operates broadly as follows: a user enters an operand, then an operator, then another operand, and finally clicks the equals button to get a result. From the programming perspective, this means that the calculator needs to parse numerical expressions, defined formally by the following BNF grammar:

```

expression ::= operand1 operator operand2 '='
operand1 ::= expression | ['+' | '-'] number
operand2 ::= ['+' | '-'] number
number ::= {'0' | '1' | ... '9'}* ['.'] {'0' | '1' | ... '9'}*
operator ::= '+' | '-' | '*' | '/'
  
```

The problem is not only to correctly parse numerical expressions, but also to do it interactively (“on the fly”). The user can provide any symbol at any time, not necessarily only the symbols allowed by the grammar in the current context. It is up to the application to ignore such symbols. (This particular application ignores invalid inputs. Often an even better approach is to actively prevent generation of the invalid inputs in the first place by disabling invalid options, for example.) In addition, the application must handle inputs not related to parsing expressions, for example Cancel (C) or Cancel Entry (CE). All this adds up to a nontrivial problem, which is difficult to tackle with the traditional event-action paradigm (see part 1 of this article series) or even with the traditional (nonhierarchical) FSM.

### 3.2 High-Level Design

Figure 3-2 shows first steps in elaborating the calculator statechart. In the very first step (panel (a)), the state machine attempts to realize the primary function of the system (the primary use case), which is to compute expressions: operand1 operator operand2 equals... The state machine starts in the “operand1” state, whose function is to ensure that the user can only enter a valid operand. This state obviously needs some internal submachine to accomplish this goal, but we ignore it for now. The criterion for transitioning out of “operand1” is entering an operator (+, −, \*, or /). The statechart then enters the “opEntered” state, in which the calculator waits for the second operand. When the user clicks a digit (0 .. 9) or a decimal point, the state machine transitions to the “operand2” state, which is similar to “operand1.” Finally, the user clicks ‘=’, at which point the calculator computes and displays the result. It then transitions back to the “operand1” state to get ready for another computation.

Figure 3-2: The first two steps in elaborating the calculator statechart

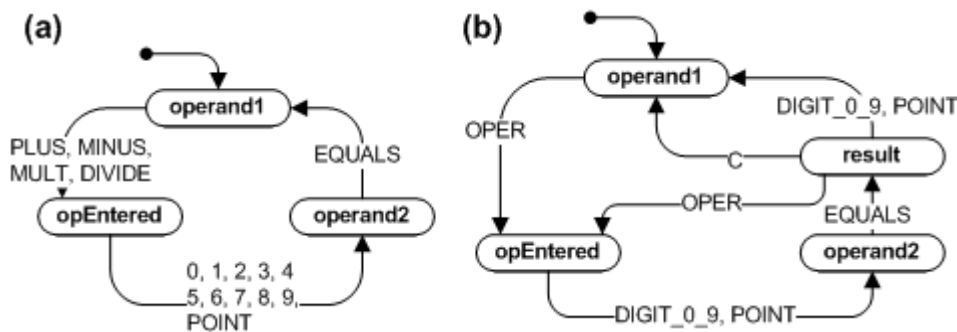

The simple state model from Figure 3-2(a) has a major problem, however. When the user clicks ‘=’ in the last step, the state machine cannot transition directly to “operand1” because this would erase the result from the display (to get ready for the first operand). We need another state “result” in which the calculator pauses to display the result (Figure 3-2(b)). Three things can happen in the “result” state: (1) the user may click an operator button to use the result as the first operand of a new computation (see the recursive production in line 2 of the calculator grammar), (2) the user may click Cancel (C) to start a completely new computation, or (3) the user may enter a number or a decimal point to start entering the first operand.

**TIP:** Figure 3-2(b) illustrates a trick worth remembering: the consolidation of signals PLUS, MINUS, MULTIPLY, and DIVIDE into a higher-level signal OPER (operand). This transformation avoids repetition of the same group of triggers on two transitions (from “operand1” to “opEntered” and from “result” to “opEntered”). Although most events are generated externally to the statechart, in many situations it is still possible to perform simple transformations before dispatching them (e.g., a transformation of raw button presses into the calculator events). Such transformations often simplify designs more than the trickiest state and transition topologies.

### 3.3 Scavenging for Reuse

The state machine from Figure 3-2(b) accepts the C (Cancel) command only in the result state. However, the user expects to be able to cancel and start over at any time. Similarly, the user expects to be able to turn the calculator off at any time. Statechart in Figure 3-3(a) adds these features in a naïve way. A better solution is to factor out the common transition into a higher-level state named “on” and let all substates reuse the C (Cancel) and OFF transitions through behavioral inheritance, as shown in Figure 3-3(b).

Figure 3-3: Applying state nesting to factorize out the common Cancel transition (C).

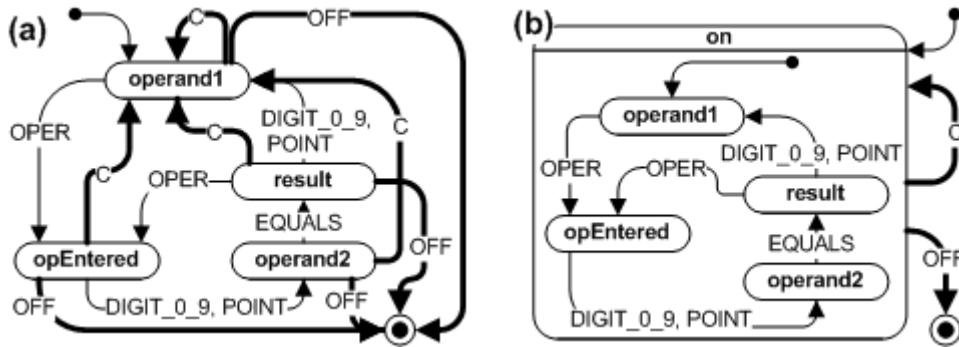

### 3.4 Elaborating Composite States

The states “operand1” and “operand2” need submachines to parse floating-point numbers. Figure 3-4 refers to both these states simultaneously as “operandX” state.

Figure 3-4: Internal submachine of states “operand1” and “operand2.”

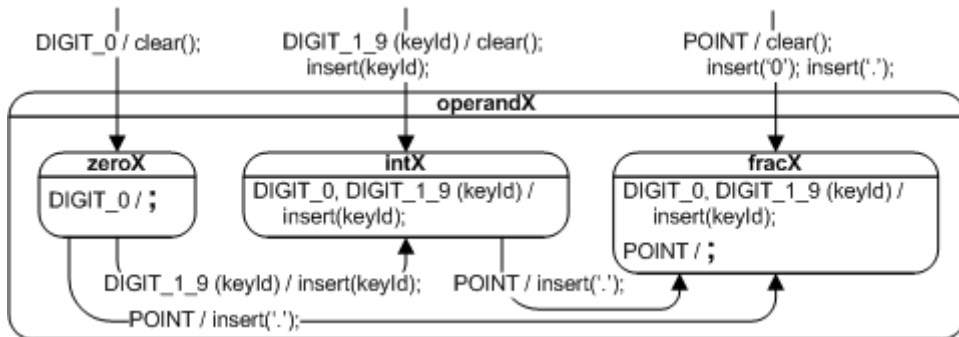

These submachines consist of three substates. The “zero” substate is entered when the user clicks 0. Its function is to ignore additional zeros that the user may try to enter (so that the calculator displays only one 0). Note my notation for explicitly ignoring an event. I use the internal transition (DIGIT\_0 in this case) followed by an explicitly empty list of functions (a semicolon in C).

The function of the “int” substate is to parse integer part of a number. This state is entered either from outside or from the “zero” peer substate (when the user clicks 1 through 9). Finally, the substate “frac” parses the fractional part of the number. It is entered from either outside or both peer substates when the user clicks a decimal point (‘.’). Again, note that the “frac” substate explicitly ignores the decimal point POINT event, so that the user cannot enter multiple decimal points in the fractional part of a number.

### 3.5 Refining the Behavior

The last step brings the calculator statechart to the point at which it can actually compute expressions. However, it can handle only positive numbers. In the next step, I will add handling of negative numbers. This turns out to be perhaps the toughest problem in this design because the same button, ‘-’ (minus), represents in some contexts the binary operator of subtraction and sometimes the unary operator of negation.

There are only two possible contexts in which ‘-’ can unambiguously represent the negation rather than the subtraction: (1) in the “opEntered” state (as in the expression: 2 \* 2 =), and (2) at the beginning of a new computation (as in the expression: 2\*2=).

**Figure 3-5: Two cases of handling negative numbers.**

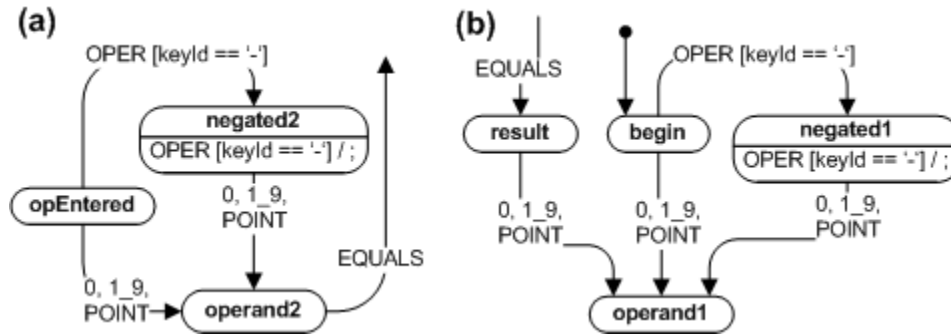

The solution to the first case (shown in Figure 3-5(a)) is simpler. We need one more state “negated2,” which is entered when the operator is MINUS (note the use of the guard). Upon entry, this state sets up the display to show ‘-0’ and subsequently does not clear the display when transitioning to the “operand2” state. This is a different behavior from “opEntered” because in this latter state the display must be cleared to prepare for entering of the second operand.

The second case in which ‘-’ represents the negation is trickier because the specification “beginning of new computation” is much more subtle. Here it indicates the situation just after launching the application or after the user clicks Cancel but not when the calculator displays the result from the previous computation. Figure 3-5(b) shows the solution. A new state “begin” is created to capture the behavior specific to the “beginning of new computation” (note the initial transition pointing now to “begin” rather than to “operand1”). The rest of the solution is analogous as in the first case, except now the state “begin” plays the role of “opEntered.”

### 3.6 Final Touches

The calculator is almost ready now. The final touches (which I leave as an exercise) include adding Cancel-Entry transitions in appropriate contexts and adding an “error” state to capture overflows and division by zero. Figure 3-6 shows the final calculator state diagram.

Figure 3-6: The final calculator statechart.

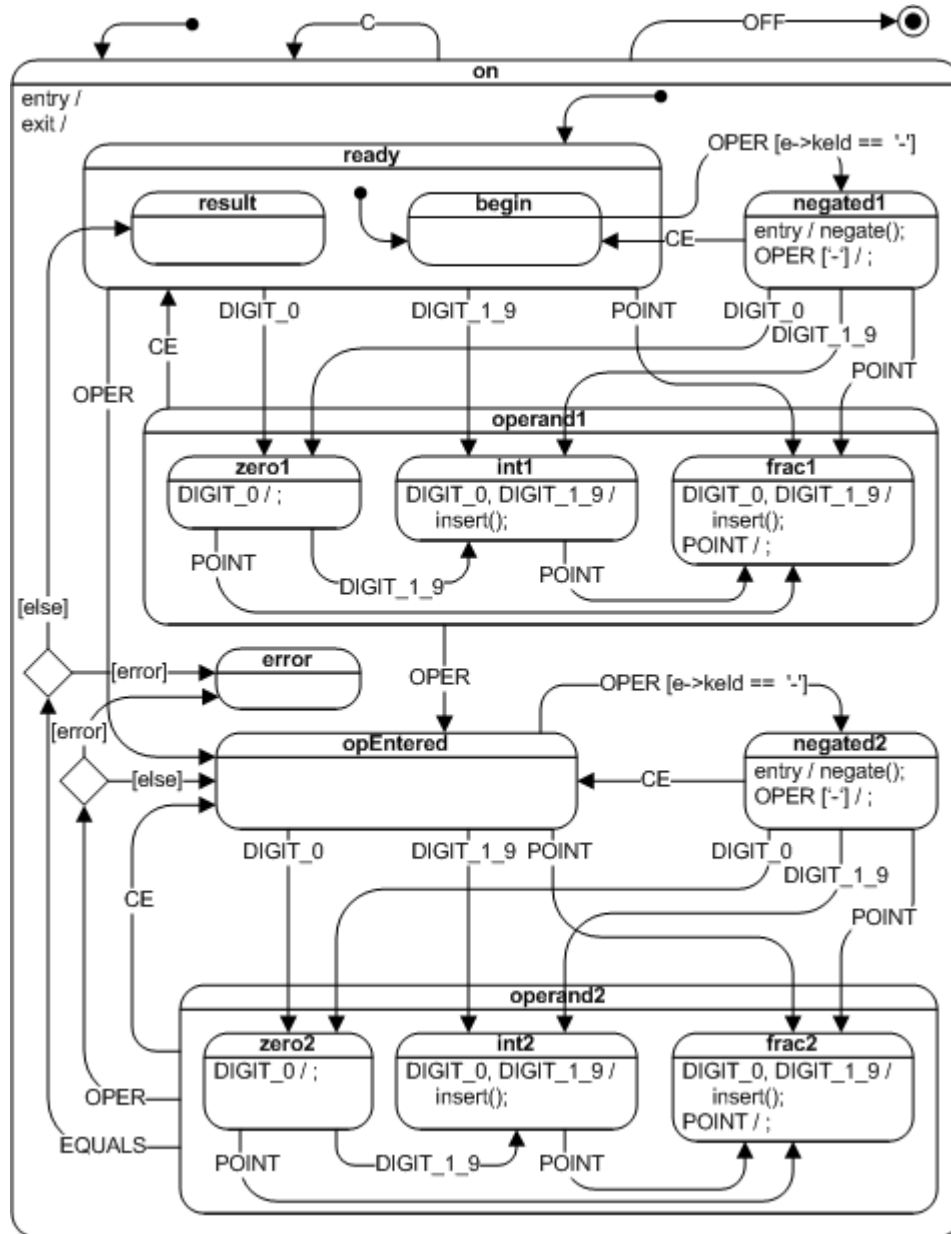

### 3.7 Executing the Example Code

The actual C and C++ implementations of the calculator hierarchical state machine from Figure 3-6 are available from the Website accompanying the book “Practical UML Statecharts in C/C++” at [www.state-machine.com/psicc2/](http://www.state-machine.com/psicc2/). The calculator example in C is found in the directory <code>\qpc\examples\80x86\dos\watcom\1\calc\</code> and the C++ version is found in the directory <code>\qpcpp\examples\80x86\dos\watcom\1\calc\</code>. The source code consists of the following files:

- `calc.h` contains the declaration of signals, events, and the Calc state machine structure.
- `calc.c` (`calc.cpp` in the C++ version) contains the implementation of the Calc state machine.

- bsp.h contains the board support package interface.
- bsp.c (bsp.cpp in the C++ version) contains the implementation of the board-specific functions.
- main.c (main.cpp in the C++ version) contains the main() function and the event loop.
- make.bat is the simple batch file for building the application.

As always, the code I provide is executable and I encourage you to try it out. You can run the example on any Windows PC by either double-clicking on the executable located in the directory

```
<qp>\qpc\examples\80x86\dos\watcom\1\calc\dbg\CALC.EXE.
```

The calculator example is interactive and you can perform computations with it. You use the keyboard to send keypress events to the application; the state of the calculator display is shown at the command prompt. The calculator recognizes keys: 0, 1, . . . , 9, ., +, -, \*, /, =, C, and E (cancel entry, CE). The Esc key terminates the application. All other keys are ignored.

Figure 3-7: The calculator HSM running in a Windows console.



```

Calculator example, QEP version: 3.4.82
Press '0' .. '9'      to enter a digit
Press '.'             to enter the decimal point
Press '+'            to add
Press '-'            to subtract or negate a number
Press '*'            to multiply
Press '/'            to divide
Press '=' or <Enter> to get the result
Press 'c' or 'C'     to Cancel
Press 'e' or 'E'     to Cancel Entry
Press <Esc>          to quit.

on-ENTRY;on-INIT;ready-ENTRY;ready-INIT;begin-ENTRY;
[ 0] 2: begin-EXIT;ready-EXIT;operand1-ENTRY;int1-ENTRY;
[ 2] -: int1-EXIT;operand1-EXIT;opEntered-ENTRY;
[ 2] -: opEntered-EXIT;negated2-ENTRY;
[ -0] -:
[ -0] 2: negated2-EXIT;operand2-ENTRY;int2-ENTRY;
[ -2] -: int2-EXIT;operand2-EXIT;ready-ENTRY;result-ENTRY;
[ 4] e: result-EXIT;ready-EXIT;on-EXIT;final-ENTRY;
Bye! Bye!
  
```

Figure 3-7 shows a screen shot in which you can see how the calculator handles the expression 2, -, -, -, 2, = that has crashed the Visual Basic calculator discussed in part 1 of this article series. I'd like to challenge you to crash the state machine-based calculator. The calculator starts with displaying zero aligned at the right edge of the display [ 0]. To the right of the display, you can see the key sent to the calculator. For example, the first key is 2. The key event is followed by the sequence of actions that the calculator HSM performs in response to the key event. I recommend that you correlate this output with the calculator state diagram from Figure 3-6.

### 3.8 Summary

The main challenge in programming event-driven systems is to identify the appropriate actions to execute in response to a given event. In general, the actions are determined by two factors: by the nature of the event and by the current context (i.e., by the sequence of past events in which the system was involved). The traditional techniques, such as the event-action paradigm, neglect the context and result in code riddled with a disproportionate amount of convoluted conditional logic that programmers call "spaghetti" code.

Techniques based on state machines are capable of achieving a dramatic reduction of the different paths through the code and simplification of the conditions tested at each branching point. A state machine makes the event handling explicitly dependent on both the nature of the event and on the context (state) of the system. States are "chunks of behavior," whereas the event-action paradigm is applied locally within each state. The concept of state

is a very useful abstraction of system history, capable of capturing only relevant sequences of stimuli (and ignoring all irrelevant ones). In extended state machines (state machines with “memory”), state corresponds to qualitative aspects of system behavior, whereas extended state variables (program memory) correspond to the quantitative aspects.

An event is a type of instantaneous occurrence that can cause a state machine to perform actions. Events can have parameters, which convey the quantitative information regarding that occurrence. Upon reception of an event instance, a state machine responds by performing actions (executing code). The response might include changing state, which is called a state transition. Classical FSMs have two complementary interpretations of actions and transitions. In Mealy automata, actions are associated with transitions, whereas in Moore automata, actions are associated with states.

State machine formalisms universally assume the run-to-completion (RTC) execution model. In this model, all actions triggered by an event instance must complete before the next event instance can be dispatched to the state machine, meaning that the state machine executes uninterruptible steps (RTC steps) and starts processing each event in a stable state configuration.

UML state machines are an advanced formalism for specifying state machines, which extends the traditional automata theory in several ways. The UML state machine formalism is a variant of extended state machines with characteristics of both Mealy and Moore automata. UML state machines include notations of nested hierarchical states and orthogonal regions as well as extending the notation of actions.

The most important innovation of UML state machines over classical FSMs is the introduction of hierarchically nested states. The value of state nesting lies in avoiding repetitions, which are inevitable in the traditional “flat” FSM formalism. The semantics of state nesting allow substates to define only the differences in behavior from the superstates, thus promoting sharing and reuse of behavior. The relation between a substate and its superstate has all the characteristics of inheritance and is called behavioral inheritance in this book. Behavioral inheritance is as fundamental as class inheritance and allows building whole hierarchies of states, which correspond to class taxonomies in OOP. Properly designed state hierarchies comply with the Liskov Substitution Principle (LSP) extended for states.

UML state machines support state entry and exit actions for states, which provide the means for guaranteed initialization and cleanup, very much as constructors and destructors do for classes. Entry actions are always executed starting with the outermost state, which is analogous to class constructors executed from the most general class. The exit actions, similar to destructors, are always executed in exact reverse order.

Entry and exit actions combined with state nesting complicate transition sequence. The precise semantics of state transitions can be confusing. The exhaustive example QHSMTST.EXE discussed in this chapter can precisely “answer” virtually all your questions regarding the semantics of state machine execution.

Statecharts were first invented as a visual formalism; therefore, they are heavily biased toward graphical representation. However, it is important to distinguish the underlying concept of the HSM from the graphical notation. It is also important to distinguish between statecharts and flowcharts.

Designing effective UML state machines is not trivial and, as with most designs, typically requires incremental, iterative process. Reuse does not come automatically, but you must actively look for it.

## 3.9 References

- [3-1] Samek, Miro, “Practical UML Statecharts in C/C++, Second Edition: Event-Driven Programming for Embedded Systems”, Newnes 2008.

## Contact Information

---

**Dr. Miro Samek** is founder and president of [Quantum Leaps](http://Quantum Leaps), an open source company providing lightweight, state machine-based, event-driven application frameworks for embedded systems. He is the author of "[Practical UML Statecharts in C/C++, Second Edition: Event-Driven Programming for Embedded Systems](#)" (Newnes 2008), has written numerous articles for magazines, including a column for *C/C++ Users Journal*, is a regular speaker at the *Embedded Systems Conferences*, and serves on the editorial review board of the *Embedded Systems Design* magazine. For a number of years, he worked in various Silicon Valley companies as an embedded software architect and before that he worked as an embedded software engineer at GE Medical Systems (now GE Healthcare). Dr. Samek earned his Ph.D. in nuclear physics at GSI (Darmstadt, Germany).

e-mail: [miro@quantum-leaps.com](mailto:miro@quantum-leaps.com)

**Quantum Leaps, LLC**  
103 Cobble Ridge Drive  
Chapel Hill, NC 27516  
USA

+1 866 450 LEAP (toll free, USA only)  
+1 919 869-2998 (FAX)  
e-mail: [info@quantum-leaps.com](mailto:info@quantum-leaps.com)  
WEB : <http://www.quantum-leaps.com>  
<http://www.state-machine.com>

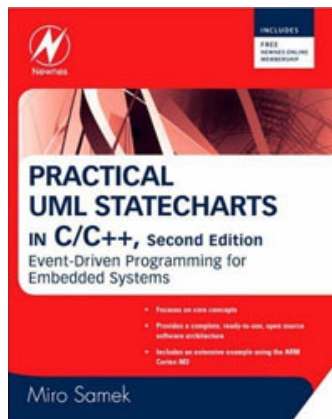

"*Practical UML Statecharts in C/C++, Second Edition: Event Driven Programming for Embedded Systems*", by **Miro Samek**, Newnes, 2008

ISBN-10: 0750687061  
ISBN-13: 978-0750687065

